



FH320 SERIES

In line pressure filters

Inline filters for operating pressure up to 320 bar, flow rate up to 150 l/min.

Available with or without bypass, indicator port is a standard option to fit a visual or electrical differential indicator.



HOUSING

tested according to NFPA T3.10.5.1, ISO 10771, ISO 3968

PRESSURE:	Max operating: 320 bar Fatigue rating: 10 ⁶ cycles 0÷320 bar
CONNECTIONS:	G 1/2" ÷ 1" - M22x1,5 on request
MATERIALS:	Head: cast iron Bowl: extruded steel Seal: NBR (FKM on request)
BYPASS VALVE:	No by-pass or 6 bar setting

ELEMENT

tested according to ISO 11170, 2941, 2942, 2943, 3724, 3968, 16889, 16908, 23181

FILTER MEDIA:	Inorganic microfiber: G01 - G03 - G06 - G10 G15 - G25
COLLAPSE PRESSURE:	21 bar 210 bar
TEMPERATURE RANGE:	with NBR seal from -30 °C to +100 °C with FKM seal (OPTION) from -25 °C to +120 °C
FLUID COMPATIBILITY:	Full with HH-HL-HM-HV HETG-HEES (acc. to ISO 6743/4). For use with other fluid please contact Filtrec Customer Service (info@filtrec.it).

OVERALL DIMENSIONS

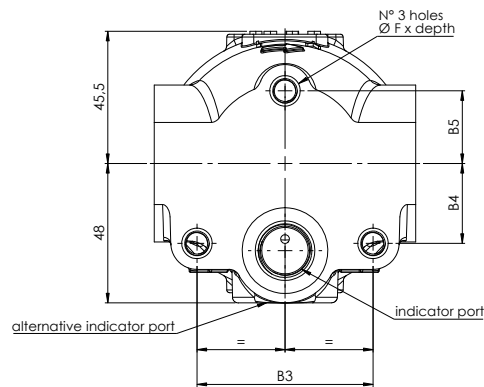
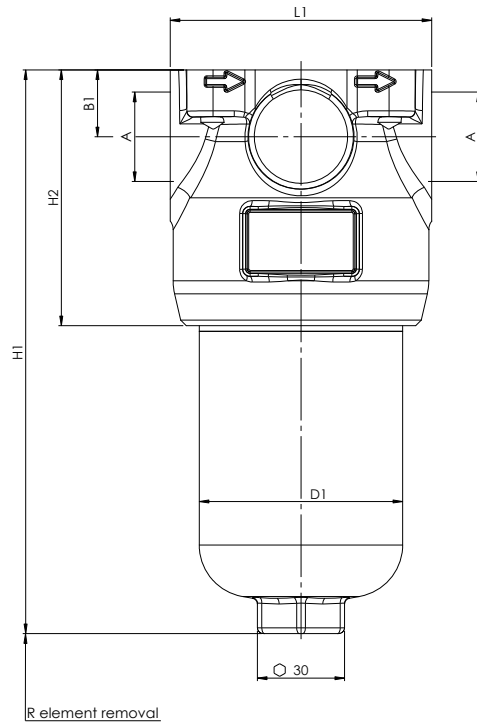

NOMINAL SIZE

MODEL	A	B1	B3	B4	B5	D1	F	H1	H2	L1	R	WEIGHT
FH320-D125								157				3,3 Kg
FH320-D120	G 1/2"							198				3,9 Kg
FH320-D124	G 3/4"	23	60,6	27,5	25	70	M10x15	241	88	90	110	4,4 Kg
FH320-D121	G 1"							291				4,9 Kg
FH320-D126	M22x1,5							335				5,3 Kg

HYDRAULIC SYMBOL

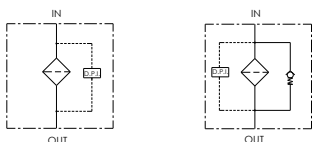

ORDERING INFORMATION

	1.	2.	3.	4.	5.	6.	7.	8.	9.	10.	11.	12.
	FH320	D1	20	G10	A	B	B3	D	W	E05	S	0
SPARE ELEMENT	D1	20	G10	A								

1. FILTER SERIES	FH320	
2. FILTER ELEMENT SERIES	D1	
3. FILTER SIZE	25-20-24-21-26	
4. FILTER MEDIA	000	no element
	G01	glassfiber $\beta_{4\mu m(c)} \geq 1.000$
	G03	glassfiber $\beta_{5\mu m(c)} > 1.000$
	G06	glassfiber $\beta_{7\mu m(c)} > 1.000$
	G10	glassfiber $\beta_{12\mu m(c)} > 1.000$
	G15	glassfiber $\beta_{18\mu m(c)} > 1.000$
	G25	glassfiber $\beta_{22\mu m(c)} > 1.000$
5. ELEMENT COLLAPSE	A	21 bar
	B	210 bar recommended with no by-pass option
6. SEALS	B	*NBR
*omitted for spare element	V	FKM
7. CONNECTIONS	B3	G 1/2"
For different thread options please check availability with Filtrac Customer Service.	B4	G 3/4"
	B5	G 1"
	M22	M22 x 1,5 (on request)
8. BYPASS VALVE	0	no by-pass
	D	6 bar
9. INDICATOR PORT OPTION	S	with metal plug
	W	with plastic plug when using an indicator
10. INDICATOR	000	no indicator
(F) digit for FKM seal option	V05 (VF5)	differential visual 5 bar
*LC24=Led connector (see clogging indicators catalogue)	E05 (EF5)	differential electrical 5 bar
	E05L (EF5L)	differential electric 5 bar + *LC24
	V08 (VF8)	differential visual 8 bar
	E08 (EF8)	differential electrical 8 bar recommended for no by-pass option
	E08L (EF8L)	differential electric 8 bar + *LC24
11. CORROSION PROTECTION	S	phosphated - standard
12. OPTIONS	0	standard

PRESSURE DROP (Δp) INFORMATION FOR FILTER SIZING

The total Delta P through a filter assembly is given from Housing Δp + Element Δp .

This ideally should not exceed 1,0 bar and should never exceed 1/3 of the set value of the by-pass valve. N.B. All the reported data have been obtained at our laboratory, according to specification ISO3968 with mineral oil having 32 cSt viscosity and density 0,875 Kg/dm³.

HOUSING PRESSURE DROP

The housing Δp is given by the curve of the considered model and port, in correspondence of the flow rate value.

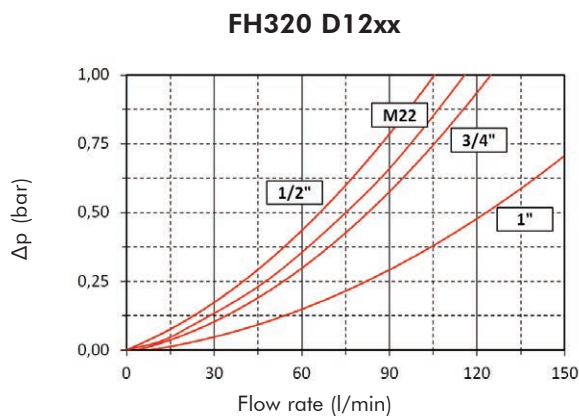

ELEMENT PRESSURE DROP (filter elements 21 bar collapse)

The element Δp (bar) is given by the flow rate (l/min) multiplied by the factor in the table here below corresponding to the selected media and divided by 1000.

If the oil has a viscosity V_x different than 32 cSt a corrective factor $V_x/32$ must be applied.

Example: 80 l/min with D121G10A and oil viscosity 46 cSt $> (80 \times 4,42)/1000 \times (46/32) = 0,51$ bar

	G01A	G03A	G06A	G10A	G15A	G25A
D125	50,24	35,56	25,75	15,51	8,27	7,57
D120	30,43	21,30	13,97	8,39	5,18	4,78
D124	19,90	13,93	8,42	5,17	4,16	3,60
D121	15,48	10,84	6,79	4,42	3,38	2,93
D126	13,24	8,61	5,75	4,03	2,91	2,43

EXAMPLE OF TOTAL Δp CALCULATION

FH320D121G10ABB5DWV05 with 80 l/min and oil 46 cSt:

Housing Δp 0,25 bar + element Δp 0,51 bar $(80 \times 4,42)/1000 \times (46/32) =$ total assembly Δp 0,76 bar

ELEMENT PRESSURE DROP (filter elements 210 bar collapse)

The element Δp (bar) is given by the flow rate (l/min) multiplied by the factor in the table here below corresponding to the selected media and divided by 1000.

If the oil has a viscosity V_x different than 32 cSt a corrective factor $V_x/32$ must be applied.

Example: 80 l/min with D121G10B and oil viscosity 46 cSt $> (80 \times 5,25)/1000 \times (46/32) = 0,60$ bar

	G01B	G03B	G06B	G10B	G15B	G25B
D125	57,38	39,23	27,50	16,53	10,15	8,03
D120	37,18	26,03	14,77	11,57	6,89	6,13
D124	24,56	17,19	11,37	6,63	4,93	3,92
D121	23,89	16,72	11,25	5,25	3,85	3,34
D126	17,65	11,48	7,79	5,17	3,55	2,85

EXAMPLE OF TOTAL Δp CALCULATION

FH320D121G10BBB5DWV08 with **80** l/min and oil **46** cSt :

Housing Δp 0,25 bar + element Δp 0,60 bar $(80 \times 5,25)/1000 \times (46/32) =$ total assembly Δp 0,85 bar

BYPASS VALVE PRESSURE DROP

The bypass valve Δp is given by the curve of the considered model and setting, in correspondence of the flow rate value.

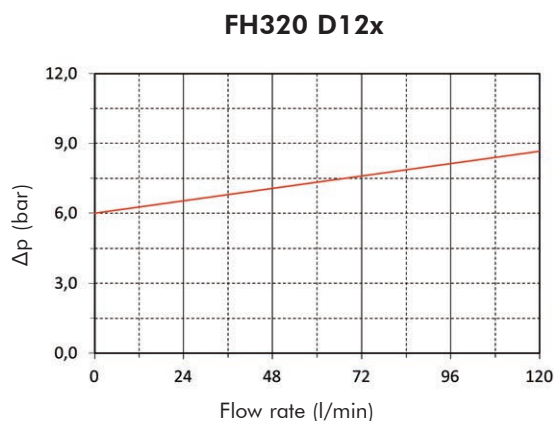

N.B. All the reported data have been obtained at our laboratory, according to specification ISO3968 with mineral oil having 32 cSt viscosity and density 0,875 Kg/dm³.

USER TIPS



INDICATOR TIGHTENING TORQUE

90 Nm

SPARE SEAL KIT PART NUMBER (6)

	NBR	FKM
FH320 D1-2x	06.021.00268	06.021.00269

BOWL TIGHTENING TORQUE

screw up filter bowl till end

WARNING

- ⚠ Make sure that Personal Protective Equipment (PPE) is worn during installation and maintenance operation.

DISPOSAL OF FILTER ELEMENT

- ⚠ The used filter elements and the filter parts dirty of oil are classified as "Dangerous waste material": they must be disposed according to the local laws by authorized Companies.

INSTALLATION

- ⚠ 1. The IN and OUT ports must be connected to the hoses in the correct flow direction an arrow shows on the filter head (1).
2. The filter housing should be preferably mounted with the bowl (5) downward.
3. Secure to the frame the filter head (1) using the threaded fixing holes (3).
4. Verify that no tension is present on the filter after mounting.
5. Enough space must be available for filter element replacement.
6. The visual clogging indicator must be in a easily viewable position.
7. When a electrical indicator is used, make sure that it is properly wired.
- ⚠ 8. Never run the system with no filter element fitted.
9. Keep in stock a spare FILTREC filter element for timely replacement when required.
10. Filter housing should be earthed.

OPERATION

- ⚠ 1. The filter must work within the operating conditions of pressure, temperature and compatibility given in the first page of this data sheet.
2. The filter element must be replaced as soon as the clogging indicator signals at working temperature (in cold start conditions, oil temperature lower than 30°C, a false alarm can be given due to oil viscosity).
3. If no clogging indicator is mounted, replace the element according to the system manufacturer's recommendations.

MAINTENANCE

- ⚠ 1. Make sure that the system is switched off and there is no residual pressure in the filter.
2. Unscrew the bowl (5) by turning it anti-clockwise and remove it.
3. Remove the dirty element (4).
4. Fit a new FILTREC element (4), verifying the part number, particularly concerning the micron rating; open its plastic protection on the open end side and insert it onto the spigot in the filter head, then remove completely the plastic protection.
5. Clean carefully the bowl; check the O-rings (6) conditions and replace if necessary.
6. Lubricate the bowl's thread (5) and screw it by hand in the filter head (1) by turning it clockwise.
7. Screw in the bowl to stop.
- ⚠ 8. The used filter elements cannot be cleaned and re-used.

