



## DX1004-T

The DX modular housing arrangement offers a flexible and space conscious solution to integrate our innovative DXO Cartridge in to both new and existing systems. The Delta-Xero system can be configured up to 12 cartridges in parallel as a single unit in a compact and easily maintainable layout.

The unit can be supplied with a number of standard options to provide an effective fluid conditioning and monitoring package to suit the majority of systems. The flexibility of the unit allows tailoring to customer's specific requirements.



### DX1004-T

Drive Input	Electric or Pneumatic
Connection Ports	3/8" BSP In & Out
Flow Indicator	Visual
Suggested System Volume	Up to 18,000l @ 32cSt
Particulate Removal	From 0.1 μ
Weight	45 kg
Dimensions	H 916 mm x D 300 mm x L 825 mm
Material	SS316
DXO Cartridge QTY	4

Flow Rate varies depending on viscosity, pressure and temperature

Approx flow at 2.7 bar:	32 cSt	46 cSt	68 cSt	100 cSt	220 cSt	320 cSt	460 cSt
	5.0 l/min	4.0 l/min	3.2 l/min	2.4 l/min	1.6 l/min	0.8 l/min	0.4 l/min
Oil Volume	18000ltrs	14000ltrs	12000ltrs	9600ltrs	7200ltrs	3200ltrs	1600ltrs

## General Arrangement

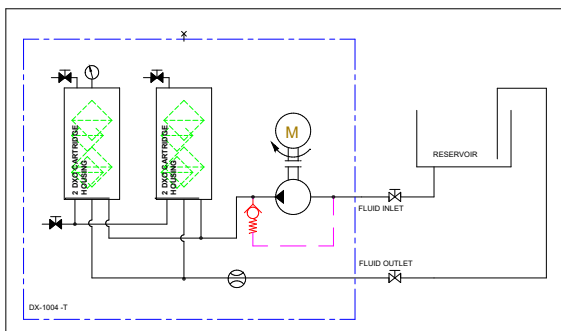
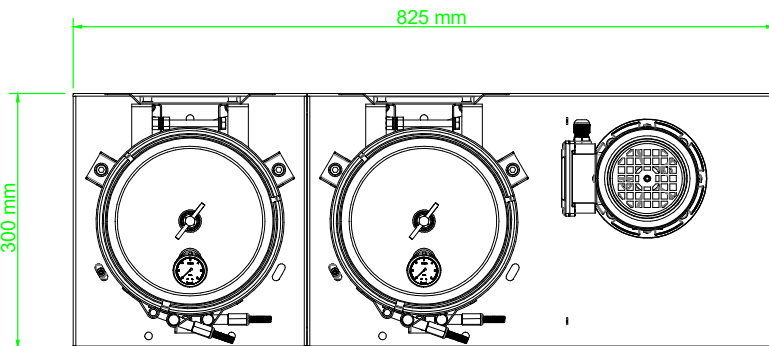
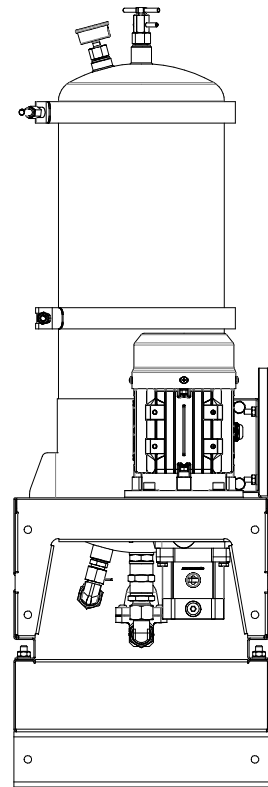
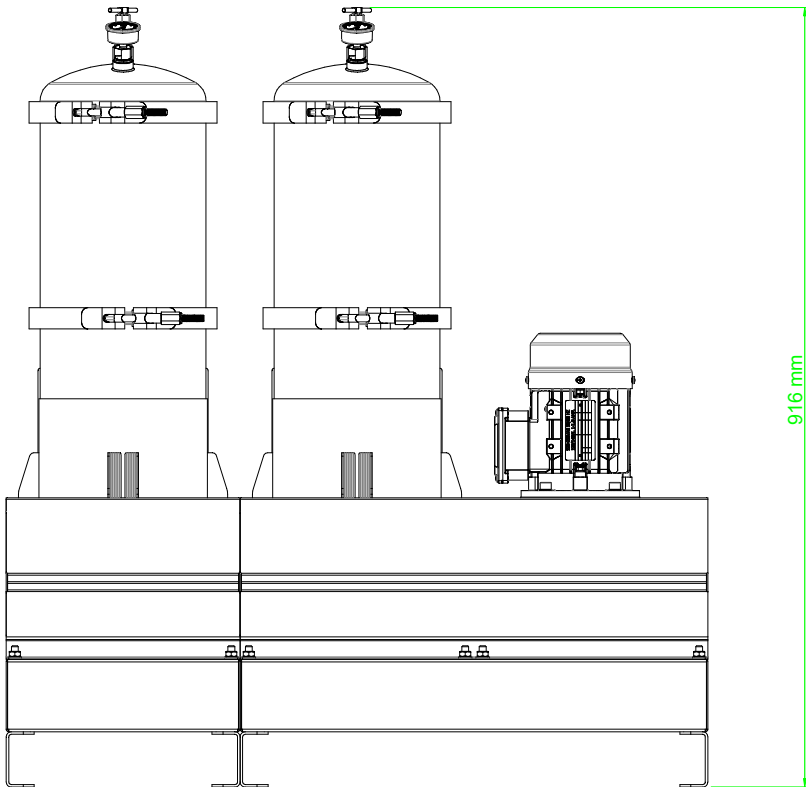

### DXO Cartridge

Contamination capacity:	Up to 4.5kg per DXO
Water absorption, free and bound:	2600ml
Material Insert:	PP Cellulose mix

